



POSTAL BULLETIN

INSTRUCTIONS AND INFORMATION FOR POSTAL EMPLOYEES

PUBLISHED WEEKLY



LXXX

Washington 25, D. C., Thursday, April 2, 1959—Seven Pages

20135

All Postal Installations

4 1/2-Cent Hermitage Stamp To Be Issued in Coils

The Department will issue the 4 1/2-cent "The Hermitage" ordinary postage stamp, in coils, perforated at the top and bottom of the stamp, on May 1, 1959, through the Denver, Colo., post office, on the occasion of the 10th annual Rocky Mountain Philatelic Exhibition.

POSTMASTERS SHALL NOT PLACE THIS STAMP ON SALE BEFORE MAY 2, 1959

The stamp features "The Hermitage," home of President Andrew Jackson, and the design is identical to the 4 1/2-cent issue of the regular series currently in use.

Collectors desiring first-day cancellations of this stamp may send addressed envelopes, together with remittance to cover the cost of the stamps to be affixed to the Postmaster, Denver 2, Colo. A close-fitting enclosure of postal card thickness should be placed in each envelope and the flap either turned in or sealed. Envelopes submitted should be of ordinary letter size and each must be properly addressed. An envelope must not be sent for return of first-day covers. Orders for covers must not include requests for uncanceled stamps. It is recommended that no more than two stamps be requested for affixment to each cover as it is practically impossible to attractively cancel a longer strip. The outside envelope to the postmaster should be endorsed "First-Day Covers 4 1/2-cent Coil Stamp."

For the benefit of collectors desiring stamps of selected quality for philatelic use, the 4 1/2-cent Hermitage coiled stamp will be available at the Philatelic Sales Agency, Post Office Department, Washington 25, D.C., on and after May 2, 1959. To insure prompt shipment, mail orders to the Agency should include no other

All City Delivery Offices

Delivery of Mail Order Catalogs

Complaints have been received that mail order catalogs are being thrown from delivery vehicles and left on porches, driveways, and other unprotected places. Numerous cases have been reported where the mishandling of these catalogs has resulted in damage and sometimes complete loss. Postmasters will caution all concerned that failure to properly deliver mail order catalogs may result in disciplinary action.—*Bureau of Operations, 4-2-59.*

stamp issues. **The Philatelic Agency does not service first day covers.**

Attention is called to the instructions of the Postmaster General requiring postmasters to submit requisitions for each new stamp issue as announced in the POSTAL BULLETIN so that ample quantities will be available at all post offices on the following day after official first-day sale.

Postmasters at first- and second-class post offices requiring this issue in minimum lots of 50 coils of 500 or 8 coils of 3,000, or the multiples outlined in Part 422.324 of the Postal Manual, will submit Form 3356, punch card requisition (using item No. 733 for coils of 500 and item No. 734 for coils of 3,000) **immediately** to the Tabulating Machine Unit, Office of the Controller, Bureau of Engraving and Printing, Washington 25, D.C. Offices requiring less than the above quantities shall submit a **separate requisition immediately** on Form 017 to their regional distributing office. Requisitions including other stamps will be delayed.

Postmasters shall post a copy of this notice on the bulletin board and give information to the press regarding the issuance of the 4 1/2-cent "The Hermitage" regular postage stamp in coils.—*Office of the Special Assistant to the Postmaster General, 4-2-59.*

All Post Offices

Reporting Outside Sales

The standards for reporting an outside sale now set forth in 321.74, Postal Manual, are revised as follows:

Fourth-class post office..	\$6. 00
Third-class post office..	10. 00
Second-class post office..	50. 00
First-class post office..	200. 00

These revised standards apply to sales since December 31, 1958.

The reporting periods in 321.751, Postal Manual, are also being changed to coincide with the postal quarterly accounting periods to facilitate regional computation of gross postal receipts. Accordingly, the report for the period since December 31, 1958, is extended to cover through April 3, 1959. Thereafter, Form 1568, *Outside Sales Report*, will be submitted on a postal quarter basis (see inside front cover of cash book for dates).

Sections 321.74 and 321.751, Postal Manual, are being amended.—*Bureau of Operations, 4-2-59.*

CONTENTS

	Page	Col.
4 1/2-Cent Hermitage Stamp in Coils	1	1
Anchoring of Street Letter Box Equipment	3	1
Arrest of Postal Offender.....	2	3
Card Forms 1901 and 1901-A...	4	1
Delivery of Mail Order Catalogs	1	2
Fraud and Unlawful Orders....	5	1
Inauguration of Airmail Service	2	1
Issuance of Money Orders.....	5	1
Overburdened Rural Routes....	4	2
Overprint on SF's 33 and 36...	2	2
Payroll Forms.....	2	1
Post Office Changes.....	4	3
Postal Supply Items.....	6	3
Reporting Outside Sales.....	1	3
Revised Form 3543.....	2	3
Stolen Canadian Money Order Forms.....	2	1
Stolen Money Order Forms....	7	1
Uruguay—Parcel Post.....	2	2
Volume of COD Transactions...	4	1

*All Post Offices***Stolen Canadian Money Order Forms**

Blank Canadian money order forms Nos. A-66,840,306 to A-66,840,500, inclusive, have been reported stolen.

Notice of this theft must be added to the list of stolen Canadian forms at all points of payment.

If any of these forms is presented, the postmaster will refuse payment and notify the postal inspector of his district.—*Bureau of Finance, 4-2-59.*

*All Postal Installations***Inauguration of Airmail Service, North Central Airlines, Inc.—AM-86**

Effective on or about April 26, 1959, airmail service will be inaugurated by North Central Airlines at Appleton, Wis.

Official cachet will be furnished for the first flight at Appleton. The usual treatment, outlined in 145.3 Postal Manual, is authorized.—*Bureau of Transportation, 4-2-59.*

*All Postal Installations***Payroll Forms**

The following forms (edition dates shown) are current and will be used effective April 4, 1959:

Form 1232, *Other Service Card* (Oct. 1957).

Form 1640, *Certificate of Additional Salary Payment* (Mar. 1959).

Form 1670, *Statement of Payroll Hours Adjustments Between Accounts* (Mar. 1959).

Form 1673, *Report of Loaned Others Hours* (Mar. 1959).

Form 1233, *Travel Card*, is obsolete. Dispose as waste paper all copies of this form and all copies of Forms 1232 and 1670 with earlier edition dates than those shown above.

Local reproduction of forms serving same purpose as the above is prohibited. Any stock on hand anywhere of such local forms must be disposed of as waste.—*Bureau of Finance, 4-2-59.*

*All Postal Installations Operating Government-Owned 4-Wheel Vehicles***Revised Overprint on SF's 33 and 36**

Revised overprint on bid forms will be available in area supply centers on or about April 1, 1959. At installations where maintenance contracts are necessary, contracts for the 1960 fiscal year must be secured on the new forms.

An initial supply of the revised 4-page forms should be requisitioned from area supply centers on Form 4750, *Special Requisition for Supplies*, using the title listed below:

Standard Forms 33 and 36, *Invitation, Bid and Award—Overprinted for Servicing and Maintenance Government-Owned Trucks.*

Advertisements should be issued as soon as the new forms are received in accordance with the instructions contained in 672.212, 672.231, and 672.232, Postal Manual.

All stocks of the old 7-page bid forms should be destroyed.

In connection with the lubrication service under the revised maintenance contract, engine oil changes will be made at 4,000-mile intervals and oil filter cartridges will be changed every 2,000 miles. This will be incorporated in Facilities Handbook, Series S-11, part 370.

Postal installations normally serviced by the Topeka Supply Center (formerly Kansas City) will requisition the revised bid forms from the Chicago Supply Center during the period April 1 through April 30, 1959.—*Bureau of Facilities, 4-2-59.*

*All Postal Installations***Uruguay—Parcel Post**

The Postal Administration of Uruguay has given notice that the suspension of parcel post service to Colonia and Nueva Palmira, announced in the POSTAL BULLETIN of March 12, 1959, applies only to the free zones in those cities.

Parcels for Colonia and Nueva Palmira, unless addressed for delivery through the free zones, are to be accepted and dispatched.—*Bureau of Transportation, 4-2-59.*

*All Post Offices Having 2d-Class Publications***Revised Form 3543**

Form 3543, *Record of Second-Class Postage*, has been revised and is now stocked in supply centers. Requisitions should be submitted immediately on Form 4750, *Special Requisition for Supplies*, for a supply of the form in keeping with the number of second-class and controlled circulation entries which are now in effect (126.16, Postal Manual). **DO NOT OVERORDER** and do not include any other items on this requisition. Dispose of as waste paper all copies of previous editions remaining on hand after a supply of the revised form has been received.

The revised form is 8 x 10½ inches in size and is designed for filing in a standard three-ring binder. The form is intended to provide a monetary reflection of each publication's deposits, charges and credit balance. Detailed information as to subscribers' copies, sample copies, zone mailings, special rates, etc., will be obtained, when necessary, from the original mailing records (Form 3541, *Computation of Second-Class Postage*, and Form 3542, *Statement Showing Number of Second-Class Publications Mailed*).

The items designated "Account No." and the first column of the revised form designated "A-Previous Balance" are for use only by those offices where posting operations are done by machine. At those offices where posting operations are done manually only columns "B" through "F" need be completed.

All second-class accounts must be converted to the revised form no later than June 26, 1959, the end of the current postal fiscal year.—*Bureau of Operations, 4-2-59.*

*All Postal Installations***Arrest of Postal Offender**

Maitland Eugene Brown for whom a wanted circular was issued by the postal inspector in charge, Fort Worth, Tex., has been apprehended and the circular concerning him should be destroyed.—*Bureau of the Chief Postal Inspector, 4-2-59.*

All Offices Having Street Letter Box Equipment

Anchoring of Street Letter Box Equipment

Drawing No. 14-261, showing approved methods of anchoring boxes, was revised February 18, 1959, to include type "H", and is reproduced below to assist postmasters in completing the project of anchoring all street letter box equipment.

Section 652.57 of the Postal Manual will be amended accordingly.—Bureau of Facilities, 4-2-59.

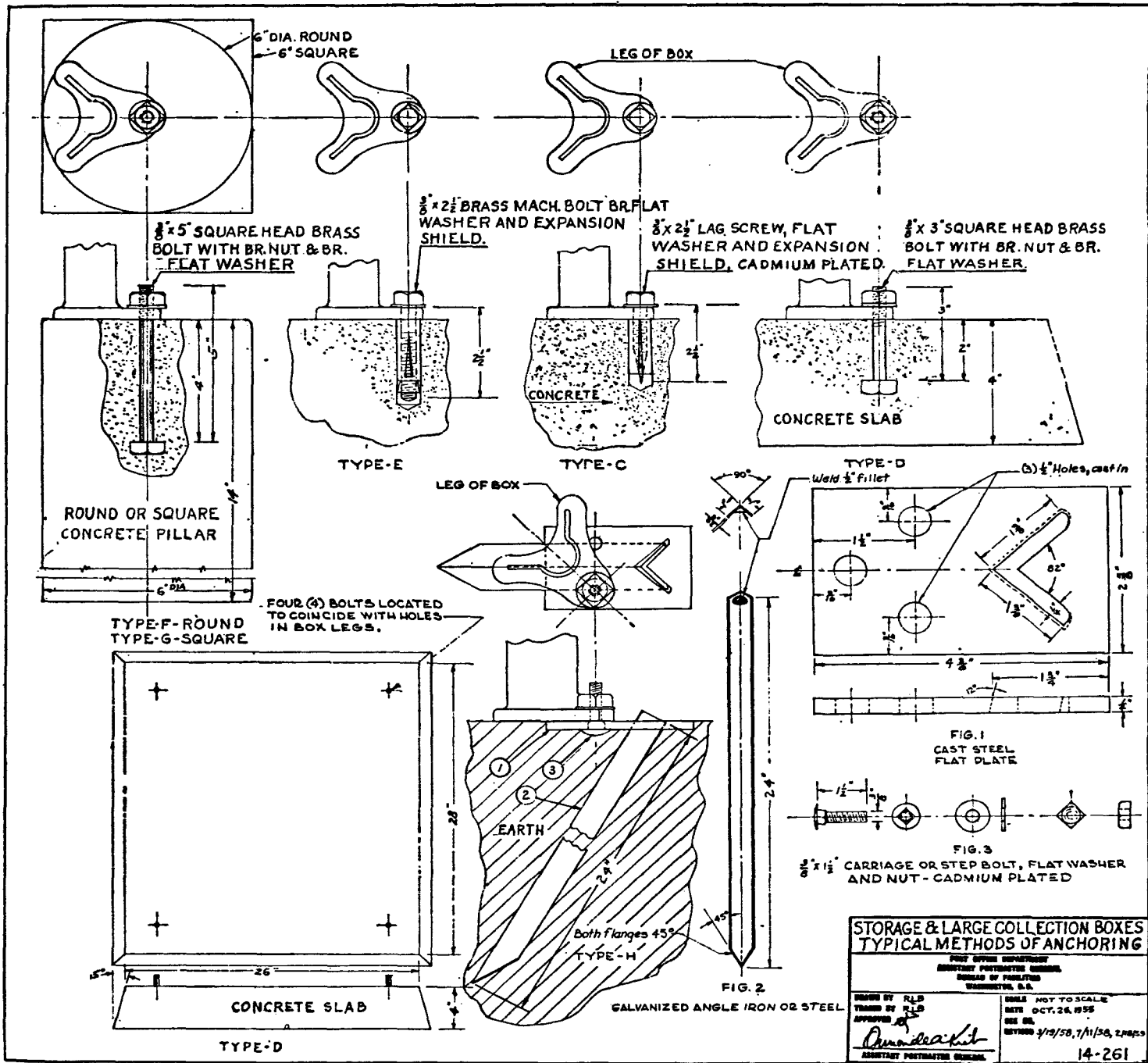

All Post Offices in the 49 States, Puerto Rico, and Virgin Islands

Preparation of Remittance Card Forms 1901 and 1901-A

Form 1901, *Remittance Card*, and Form 1901-A, office copy, replaced CX-1, *Remittance Card*, and CX-2, office copy, in March 1958. All post offices previously using card punch remittance Forms CX-1 and CX-2 should now have a supply of the new Forms 1901 and 1901-A.

In completing this new form, postmasters making cash remittances to their regional depository must complete the portion on the reverse side, showing number of pieces of currency of each denomination, dollar value and total. The total must agree with the figure on line 1 on the face of the form.—*Bureau of Finance, 4-2-59.*

All 1st- and 2d-Class Post Offices

Volume of COD Transactions

This notice is particularly directed to the attention of postmasters at those offices where a special method of accepting COD mailings has been authorized during the last several years. This method involves the acceptance of COD shipments without maintenance of the usual post office record of the mailings.

There is reason to believe that the steady decline in the number of COD mailings reported over the last several years may have resulted in part from the failure of postmasters to take into account the number of COD packages accepted without maintenance of a post office record.

Postmasters at offices of the first and second classes where firms using the COD service extensively are located will immediately determine whether or not there have been included in past reports on Form 835, *Quarterly Report of Domestic Registered and COD Transactions*, those COD mailings for which post office records have not been maintained under the special procedure.

If these mailings have not been included in volume reports submitted for previous quarters, take the following action:

1. Establish a method by which the number of COD packages mailed

All Offices With Rural Routes

Overburdened Rural Routes

Despite instructions in 353.14, Postal Manual, and repeated notices in the POSTAL BULLETIN, postmasters are not giving prompt attention to overburdened rural routes.

Forms 4240, *Rural Carrier's Trip Report*, must be examined by postmasters at least quarterly to determine whether the average daily time required to serve the route indicates relief is needed or whether heavy duty allowance should be authorized or adjusted. Field services officers on visits to offices with rural routes, similarly will review Forms 4240.

Postmasters must thoroughly familiarize themselves with the instructions set forth in 353.14, Postal Manual, in connection with heavily patronized and overburdened rural routes and comply with same. No carrier should be required to work more than 48 hours weekly. Heavy duty compensation should be authorized when such compensation is warranted.

When a carrier fails to meet the time standards in 353.143, Postal Manual, heavy duty compensation will not be authorized or increased beyond the amount he would have been entitled to had he met the time standards.

Immediate and continuing attention is to be given to prevent rural routes from becoming overburdened and to make certain that the compensation received by the carrier is in compliance with the law and the service rendered.—*Bureau of Operations, 4-2-59.*

without maintenance of a post office record will be available for inclusion in each quarterly volume report on Form 835 beginning with postal quarter III.

2. Determine as nearly as possible the number of these COD mailings that have not been included in reports for the two previous quarters of postal fiscal year 1959.

3. Show as a footnote on Form 835 for postal quarter III the number of COD mailings under the special procedure that were not included in the two previous quarterly reports for postal fiscal year 1959.—*Bureaus of Operations and Finance, 4-2-59.*

POST OFFICE CHANGES NO. 40

ALABAMA

Anniston: Saks (contract Branch), Calhoun County, *estab.* effective May 1, 1959.

ALASKA

02-14040 Chenega, Third Judicial Division (4th class), *winter post office* closes Apr. 18, 1959. Mail to Cordova, Alaska.

ARKANSAS

04-06660 Beebe, White County (2d class): *International money order* business disc. effective Mar. 26, 1959.

04-70200 Pine City, Monroe County (4th class), *disc.* effective Mar. 31, 1959. Mail to Holly Grove, Ark.

CALIFORNIA

Bellflower: No. 5 (contract Station), Los Angeles County, *estab.* effective Apr. 16, 1959.

Merced: Castle Air Force Base Money Order Unit No. 1, Merced County, *changed in designation* to Castle Air Force Base (classified Branch), effective Apr. 20, 1959.

Bakersfield: Flower Village (contract Branch), Kern County, *disc.* effective Apr. 30, 1959.

05-31380 Green Valley Lake, San Bernardino County (4th class), *summer seasonal post office* converted to a year-round office, effective May 1, 1959.

05-41460 Lakeside, San Diego County (2d class): Notice authorizing establishment of city delivery service at this office, effective Apr. 4, 1959, which appeared in the BULLETIN of Feb. 12, 1959, is *amended* to show the effective date as May 2, 1959.

05-46440 McFarland, Kern County (2d class): *City delivery service* established effective May 2, 1959.

05-70200 Santee, San Diego County (2d class): *City delivery service* established effective May 2, 1959.

DELAWARE

Newark: Notice authorizing establishment of Ogleton (contract Branch), New Castle County, effective Mar. 18, 1959, which appeared in the POSTAL BULLETIN of Mar. 26, 1959, is *modified* to show the name of the branch as Ogletown.

DISTRICT OF COLUMBIA

Washington: No. 22 (contract Station), *estab.* effective Mar. 23, 1959.

FLORIDA

Jacksonville: No. 15 (contract Station), Duval County, *estab.* effective Apr. 16, 1959.

11-65550 Oakland, Orange County (3d class): *International money order* business disc. effective Mar. 27, 1959.

11-94950 Wewahitchka, Gulf County (2d class): *International money order* business disc. effective Mar. 23, 1959.

ILLINOIS

16-85020 Wilson, Lake County (3d class), *disc.* effective Apr. 30, 1959. Mail to Waukegan, Ill.

INDIANA

Indianapolis: No. 4 (contract Station), Marion County, *disc.* effective Mar. 1, 1959.

(Continued on p. 5)

All Post Offices

Issuance of Money Orders

Information has been received that on some of the money orders being cleared for payment the issuing employee failed to enter the dollar amount in the dollars and cents block.

It is of the utmost importance that the whole dollar amount be written in words on the *Pay* line but it is also necessary that the entire amount (dollars as well as cents) be entered in figures in the amount block. Also, the rubber *amount control* stamp must be affixed in the blank space following the words *Not Valid for More Than*.

For the information of all concerned a specimen order is illustrated below and postmasters should see that employees exercise care to properly complete the form.—*Bureau of Finance, 4-2-59.*

United States Postal Money Order
 MAXIMUM VALUE ONE HUNDRED DOLLARS

PAY *Eighteen* DOLLARS *U.S.* AND CENTS AS SHOWN IN AMOUNT BLOCK *18* DOLLARS *50* CENTS

NOT VALID FOR MORE THAN **TWENTY DOLLARS** *Canadian \$7.76*

PURCHASER-FILL IN INFORMATION BELOW

PAY TO: PATTEE'S NAME

FROM: PURCHASER'S NAME

PURCHASER'S STREET ADDRESS

PURCHASER'S CITY AND STATE

IF C.O.D. ENTER IN HERE

PLEASE CASH PROMPTLY — VOID IF ALTERED
 DO NOT FOLD, STAPLE, SPINDLE OR MUTILATE

U.S. Postal Money Order

PURCHASER'S RECEIPT FILL IN OTHER SIDE

DETACH AND HOLD

PURCHASER ASSUMES RESPONSIBILITY FOR FILLING IN HIS NAME AND ADDRESS AND NAME OF PAYEE IN SPACES PROVIDED ON THE ORDER

POST OFFICE RECORD

INITIAL OF ISSUING EMPLOYEE

Notices:

Foreign Fraud Orders:

Country and city	Name and address covered by order
British West Indies:	
Allman Town P.O., Jamaica...	Gordon, Paul, P.O. Box 15; Kerr, Ernest E., 7C Stanford Street; Reid, June, P.O. Box 21.
Windward Road P.O., Jamaica	James, Carmen, 17 Leicester Ave., White Hall Gardens.
Cross Roads P.O., Jamaica....	Ashman, George G., P.O. Box 71; Baker, H., P.O. Box 62; Bennett, Grace, P.O. Box 11; Cain, Margaret, P.O. Box 129; Hamilton, Joyce, P.O. Box 166; Mosso, L., P.O. Box 174; Randall, Dezra, Mrs., P.O. Box 179; Rush, Gold, P.O. Box 154; White, Diana, P.O. Box 80.
Half-Way Tree P.O., Jamaica..	Payne, Gloria, Miss, P.O. Box 89; Russell, Nancy, Miss, P.O. Box 89; Schill, C., P.O. Box 9.
Jones Town P.O., Jamaica....	Edwards, C., Miss, P.O. Box 15; Harrison, Geo., P.O. Box 15; Linton, G. G., 67 Myers Street; P.O. Box 15; Shim, I., Miss, P.O. Box 15; Warrel, May, Mrs., P.O. Box 15.
Kingston, Jamaica.....	Allan, Conor H., P.O. Box 1995; Antonio, R., P.O. Box 29; Chelsea, Richard, P.O. Box 1228; Chung, Nellie, 32 Deanery Road; Dalley, Christopher, P.O. Box 1140; Davis, Geo., P.O. Box 117; Davis, Geo., P.O. Box 62; DePass, R., P.O. Box 28; Duncan, F., P.O. Box 28; Dwyer, B., P.O. Box 123;

(Continued on p. 6)

POST OFFICE CHANGES NO. 40

(Continued from p. 4)

INDIANA

Indianapolis: No. 43 (contract Station), Marion County, *disc.* effective Mar. 17, 1959.

Indianapolis: Haughville (classified Station), Marion County, *changed in name* to Rainbow (classified Station), effective Nov. 9, 1958.

IOWA

18-58950 Menlo, Guthrie County (3d class): *International money order* business *disc.* effective Mar. 26, 1959.

18-66780 Oakland, Pottawattamie County (2d class): *International money order* business *disc.* effective Mar. 26, 1959.

LOUISIANA

Leesville: Money Order Units No. 1, 2, 3, 4, 5, 6, 7, 8, 9, 10, 11, 12, attached to Fort Polk (classified Branch), Vernon County, *disc.* effective Mar. 31, 1959.

MARYLAND

23-69480 Palmers, Saint Marys County (4th class), *disc.* effective Apr. 30, 1959. Mail to Coltons Point, Md.

MINNESOTA

26-71700 Osseo, Hennepin County (1st class): *City delivery service* estab. effective May 2, 1959.

MISSISSIPPI

27-59150 Parchman, Sunflower County (3d class), *disc.* effective Mar. 31, 1959. Mail to Parchman, Independent rural Station, Drew, Miss.

Drew: Parchman (rural Station), Sunflower County, *estab.* effective Apr. 1, 1959. (Station will be *independent* for receipt and dispatch of registered and other mail.)

MISSOURI

28-39240 Hunnewell, Shelby County (3d class): *International money order* business *disc.* effective Mar. 26, 1959.

NEW MEXICO

34-33600 Galisteo, Santa Fe County (4th class), *disc.* effective Mar. 31, 1959. Mail to Lamy, N. Mex.

NORTH CAROLINA

Sapphire, Post Office, Transylvania County, is in Unit 1628, instead of 1678.

OREGON

40-93600 Winchester Bay, Douglas County (3d class), *disc.* effective May 31, 1959. Mail to Reedsport, Ore.

PENNSYLVANIA

Chester: Brookhaven (contract Branch), Delaware County, *estab.* effective Apr. 1, 1959.

41-56360 Mountindale, Cambria County (4th class), *disc.* effective Mar. 20, 1959. Mail to Fallentimber, Pa.

Reading: No. 12 (contract Station), Berks County, *changed in designation and name* to West Reading (contract Branch), effective Mar. 27, 1959.

(Continued on p. 6)

Notices:**Foreign Fraud Orders:***(Continued from p. 5)**Country and city*British West Indies—Continued
Kingston, Jamaica-----*Name and address covered by order*

Elliott, F., Esq., P.O. Box 1090;
 Elliott, L., P.O. Box 30;
 Evans, C., P.O. Box 28;
 Francis, Martin, P.O. Box 912;
 Fundichelli, D., 8 Lancelin Ave.;
 Geraldo, Fergie, P.O. Box 1152;
 Gideon, I., P.O. Box 135;
 Giles, L. G., P.O. Box 166, Half-Way Tree
 P.O.;
 Goodlady, Sarah, P.O. Box 1228;
 Grant, C. L. & Sons Ltd., P.O. Box 34;
 Greene, Ann, P.O. Box 164;
 Harrison, Andel, P.O. Box 343;
 Heloise, V., Mrs., P.O. Box 282;
 Hicks, A. R., P.O. Box 30;
 Hose, L., Mr. 23 Widcombe Road;
 Hovik, M., Mrs., P.O. Box 305;
 Ignatius, Capt. R., P.O. Box 1140;
 Ivy, B., P.O. Box 135;
 Jones, A. Alec, Esq., P.O. Box 345;
 Judd, P., Miss, P.O. Box 175;
 Kelly, C. & Sons Ltd., P.O. Box 110;
 Kennedy, L., Mrs., P.O. Box 110;
 Laing, R., P.O. Box 11;
 Lentz, F., P.O. Box 35;
 Linton, G. G., P.O. Box 64;
 McCarthy, R., P.O. Box 28;
 McKay, E., P.O. Box 180;
 Martin-Donald, O., P.O. Box 382;
 Meyers, A., 8 Lancelin Ave.;
 Montgomery, A., P.O. Box 1995;
 Morais, Madame J., P.O. Box 912;
 Munez, A., P.O. Box 123;
 Myers, E., P.O. Box 11;
 Nickle, M., Miss, P.O. Box 81;
 Patterson, L., Miss, P.O. Box 1152;
 P.O. Box 28;
 P.O. Box 110;
 Richard, Louis, P.O. Box 345;
 Rick-Mann, D. O., P.O. Box 502;
 Rudole, J., P.O. Box 124;
 Rudolf, J., 10 Clovelly Road;
 Ruff, E., Mr., P.O. Box 364;
 Sandy, R., Miss, 7, Hillcrest Ave.;
 Saunders, K., P.O. Box 63;
 T. C. Sales & Service Co., P.O. Box 502;
 Thompson, Norma, Mrs., P.O. Box 178;
 Chung, Sadie, P.O. Box 343.
 Cossey, B., P.O. Box 23;
 Jacobs, Rose, Mrs., P.O. Box 28;
 Scott, K., P.O. Box 27.
 West Indies Exports, 12 King Street.
 V. Parker, P.O. Box 32;
 Vincent Parker, P.O. Box 32.
 Chung, C. L., P.O. Box 34;
 Lyon's Art Service, P.O. Box 2;
 Miller, H. S. & Co., P.O. Box 36.
 A. T. Gagnon;
 A. T. Gagnon, Manager.
 Duggan, W., 16 Celtic Park Ave.
 Herzog, E., Postfach 7221.

Liguanea P.O., Jamaica-----

Montego Bay, Jamaica-----

Vineyard Town P.O., Jamaica-----

Windward Road P.O., Jamaica-----

Canada, Vancouver, B.C.-----

Ireland, Beaumont, Dublin-----

West Germany, Hamburg 47-----

Domestic Fraud Orders:*State and city**Name covered by order*

New Jersey, Newark-----

Spot Reducer Co.;
 Spot Reducer Company;
 The "Spot Reducer" Co.;
 Body Massager.

New York, New York-----

Continental TV Co.

Domestic Unlawful Orders:*State and city**Name covered by order*

New York, New York-----

Jefferson Creations, Inc.;
 Milco Specialties.

*All Post Offices***Postal Supply Items**

POD Label 62 (gummed), *First-Class Mail*, has been adopted for use by patrons on first-class packages and flats to help insure their identification and treatment as first-class mail.

POD Schedule 6, *Schedule of Charges for Stamp Sales*, has been adopted for use by stamp clerks to facilitate the sale of multiple quantities of postage stamps of the 3¢, 4¢, and 7¢ denominations.

A sufficient supply of these items to last for one requisitioning period should be ordered on your next regularly scheduled requisition. Do not submit a special requisition.—*Bureau of Operations, 4-2-59.*

POST OFFICE CHANGES NO. 40*(Continued from p. 5)***SOUTH CAROLINA**

45-11600 Calhoun Falls, Abbeville County (2d class): *City delivery service* estab. effective Apr. 18, 1959.

SOUTH DAKOTA

46-90360 Wall, Pennington County (2d class): *International money order business disc.* effective Mar. 28, 1959.

TEXAS

Amarillo: Money Order Unit No. 1, Potter County, *changed in name to Amarillo Air Force Base Money Order Unit*, effective Apr. 1, 1959.

48-98050 Wink, Winkler County (2d class): *International money order business disc.* effective Apr. 3, 1959.

VIRGINIA

Richmond: No. 10 (contract Station), Henrico County, *reestab.* effective Mar. 16, 1959.

WEST VIRGINIA

55-02700 Arcola, Webster County (4th class), *disc.* effective Apr. 30, 1959. Mail to Cowen, W. Va.

55-40860 Jerryville, Webster County (4th class), *disc.* effective Apr. 30, 1959. Mail to Bolair, W. Va.

55-76380 Sparks, Nicholas County (4th class), *disc.* effective Apr. 30, 1959. Mail to Keslers Crosslanes, W. Va.

Walk, Don't Run Downstairs**A fall is no fun**

All Post Offices

Warning Notice—Stolen Money Order Forms

The following is a current list of stolen money order forms that have not been recovered. Post this notice at windows for information of clerks. Destroy all previous notices.

- | | | |
|-------------------------------|--------------------------------|---------------------------------|
| 1-44,141,472 to 1-44,141,700 | 5-75,693,033 to 5-75,693,067 | 10-42,063,401 to 10-42,064,000 |
| 1-46,553,723 to 1-46,553,739 | 5-75,406,301 to 5-75,406,600 | 10-42,068,001 to 10-42,068,300 |
| 1-55,174,898 to 1-55,175,000 | 5-97,851,229 to 5-97,852,000 | 10-86,542,821 to 10-86,546,000 |
| 1-85,848,756 to 1-85,848,800 | 5-98,835,997 to 5-98,836,000 | 10-86,566,471 to 10-86,566,600 |
| 1-86,256,184 to 1-86,256,212 | 6-25,049,914 to 6-25,050,000 | 10-86,936,101 to 10-86,936,500 |
| 2-34,741,803 to 2-34,741,815 | 6-31,718,090 to 6-31,718,500 | 10-88,348,647 to 10-88,348,800 |
| 2-39,862,273 to 2-39,862,500 | 6-34,171,976 to 6-34,172,000 | 10-88,457,001 to 10-88,457,300 |
| 2-40,244,413 to 2-40,244,500 | 6-37,570,301 to 6-37,570,400 | 10-88,976,018 to 10-88,976,500 |
| 2-42,065,412 to 2-42,066,000 | 6-39,344,407 to 6-39,345,000 | 10-89,717,483 to 10-89,717,499* |
| 2-58,970,519 to 2-58,970,549 | 6-40,948,563 to 6-40,948,700 | 10-97,741,943 to 10-97,742,000 |
| 2-58,970,672 to 2-58,971,000 | 6-43,599,985 to 6-43,600,000 | 11-58,651,387 to 11-58,651,500 |
| 2-83,739,292 to 2-83,739,333 | 6-45,010,322 to 6-45,011,000 | 11-58,940,279 to 11-58,940,305 |
| 2-83,792,001 to 2-83,792,200 | 6-46,096,793 to 6-46,097,000 | 11-59,018,727 to 11-59,018,799 |
| 2-83,993,657 to 2-83,994,000 | 6-50,691,515 to 6-50,692,000 | 11-59,538,097 to 11-59,538,300 |
| 2-94,483,181 to 2-94,483,300 | 6-55,875,923 to 6-55,876,000 | 11-60,411,237 to 11-60,411,251 |
| 3-58,600,923 to 3-58,601,000 | 6-56,161,641 to 6-56,161,700 | 11-61,695,736 to 11-61,696,000 |
| 3-59,849,318 to 3-59,849,500 | 6-56,895,057 to 6-56,896,000 | 11-63,813,813 to 11-63,813,818 |
| 3-68,908,901 to 3-68,909,200 | 6-82,916,303 to 6-82,916,366 | 11-64,475,734 to 11-64,476,000 |
| 3-70,355,884 to 3-70,355,900 | 6-82,967,687 to 6-82,968,000 | 11-66,129,362 to 11-66,129,500 |
| 3-71,677,339 to 3-71,677,352 | 6-84,235,483 to 6-84,235,550 | 11-66,130,021 to 11-66,130,029 |
| 3-86,463,001 to 3-86,464,000 | 6-84,580,335 to 6-84,580,400 | 11-66,130,067 to 11-66,130,072 |
| 3-86,931,011 to 3-86,931,500 | 6-84,756,850 to 6-84,757,200 | 11-66,402,428 to 11-66,402,500 |
| 3-87,114,633 to 3-87,114,700 | 6-86,132,397 to 6-86,133,000* | 11-72,019,399 to 11-72,019,479 |
| 3-87,510,761 to 3-87,511,200 | 7-5,858,431 to 7-5,858,468 | 11-81,181,782 to 11-81,182,000 |
| 4-4,594,629 to 4-4,594,800 | 7-9,035,905 to 7-9,036,000 | 11-81,932,188 to 11-81,932,500 |
| 4-5,783,481 to 4-5,783,500 | 7-19,240,548 to 7-19,240,600 | 11-82,036,223 to 11-82,036,400 |
| 4-15,916,561 to 4-15,916,599 | 7-21,838,129 to 7-21,838,166 | 11-82,496,198 to 11-82,496,200 |
| 4-18,795,667 to 4-18,795,700 | 7-24,312,079 to 7-24,312,500 | 11-82,724,382 to 11-82,725,000 |
| 4-18,817,675 to 4-18,818,000 | 7-25,626,285 to 7-25,626,464 | 11-83,284,001 to 11-83,284,200 |
| 4-18,847,836 to 4-18,850,000 | 7-26,000,499 to 7-26,000,700 | 12-17,879,004 to 12-17,879,021 |
| 4-20,141,820 to 4-20,142,000 | 7-30,316,302 to 7-30,316,311 | 12-24,983,586 to 12-24,983,593 |
| 4-20,188,082 to 4-20,188,500 | 7-31,109,881 to 7-31,110,000 | 12-26,172,950 to 12-26,173,000 |
| 4-22,271,198 to 4-22,272,000 | 7-32,868,555 to 7-32,868,569 | 12-30,682,501 to 12-30,683,000 |
| 4-23,243,751 to 4-23,244,000 | 7-35,123,917 to 7-35,124,000 | 12-31,589,109 to 12-31,589,150 |
| 4-23,611,868 to 4-23,612,000 | 7-39,078,001 to 7-39,080,000 | 12-38,391,712 to 12-38,391,800 |
| 4-26,340,001 to 4-26,341,000 | 7-87,356,570 to 7-87,356,605 | 12-39,697,373 to 12-39,698,000 |
| 4-27,980,401 to 4-27,980,800 | 7-88,287,830 to 7-88,287,851 | 12-40,224,301 to 12-40,224,400 |
| 4-29,713,945 to 4-29,714,000 | 8-4,407,001 to 8-4,407,200 | 12-40,709,677 to 12-40,709,700 |
| 4-35,270,001 to 4-35,274,000 | 8-6,589,683 to 8-6,590,000 | 12-42,860,314 to 12-42,860,400 |
| 4-41,718,801 to 4-41,719,000 | 8-12,995,186 to 8-12,995,190 | 12-85,569,046 to 12-85,569,300 |
| 4-44,427,287 to 4-44,428,000 | 8-38,940,744 to 8-38,941,000 | 13-11,078,467 to 13-11,078,500 |
| 4-49,874,662 to 4-49,875,000 | 8-39,523,801 to 8-39,524,000 | 13-19,102,921 to 13-19,103,000 |
| 4-78,760,051 to 4-78,760,500 | 8-40,008,126 to 8-40,008,500 | 13-19,364,001 to 13-19,364,500 |
| 4-81,622,351 to 4-81,622,400 | 8-40,353,101 to 8-40,353,200 | 13-19,615,892 to 13-19,616,000 |
| 4-82,722,161 to 4-82,722,300 | 8-40,672,046 to 8-40,672,061 | 13-19,711,551 to 13-19,711,575 |
| 4-83,504,212 to 4-83,504,400 | 8-50,442,100 to 8-50,442,683 | 13-20,566,208 to 13-20,566,400 |
| 4-83,864,750 to 4-83,864,800 | 8-90,336,575 to 8-90,336,800 | 13-20,612,264 to 13-20,612,270 |
| 4-84,563,209 to 4-84,563,221 | 9-26,024,045 to 9-26,024,300 | 14-4,581,379 to 14-4,581,400 |
| 5-28,970,590 to 5-28,971,000 | 9-27,991,679 to 9-27,991,692 | 14-14,111,026 to 14-14,111,200 |
| 5-31,919,336 to 5-31,919,400 | 9-27,993,371 to 9-27,993,394 | 14-14,133,742 to 14-14,133,750 |
| 5-32,783,101 to 5-32,783,500 | 9-75,444,064 to 9-75,444,250 | 14-14,572,218 to 14-14,572,277 |
| 5-34,917,870 to 5-34,917,900 | 9-75,924,935 to 9-75,925,000 | 14-14,572,406 to 14-14,572,499 |
| 5-42,300,777 to 5-42,300,800* | 9-76,110,986 to 9-76,111,000 | 15-4,676,754 to 15-4,676,800 |
| 5-73,941,902 to 5-73,942,000 | 9-82,407,523 to 9-82,408,000 | 15-16,468,616 to 15-16,468,800 |
| 5-73,965,631 to 5-73,965,650 | 10-4,273,306 to 10-4,273,310 | 15-18,149,790 to 15-18,149,900 |
| 5-74,030,082 to 5-74,030,200 | 10-22,755,253 to 10-22,755,500 | 15-20,339,901 to 15-20,340,000 |
| 5-74,533,528 to 5-74,533,600 | 10-23,331,264 to 10-23,331,500 | |
| 5-74,971,207 to 5-74,971,344 | 10-41,138,258 to 10-41,138,500 | |

*Published for first time.